

Lloyd's mirror experiment with an He-Ne-Laser

Objects of the experiments

- Observing the two-beam interference of the direct and the reflected beam
- Determining the wavelength of the laser

Principles

The nature of light was a controversial issue for a long time. In 1690, *Christiaan Huygens* interpreted light as a wave phenomenon; in 1704, *Isaac Newton* described the light beam as a current of particles. This contradiction was resolved by quantum mechanics, and the idea of wave-particle duality came up.

In the 18th and 19th centuries, interference experiments contributed a lot to the decision regarding the nature of light. According to the common principle which characterizes these experiments, wave-optical methods – such as reflection, refraction, blocking and beam spitting – allow the creation of two interfering light bundles from the light emitted by a source. Therefore this method of superimposing light is called two-beam interference.

Following a method of *H. Lloyd* (1839), the light bundle from a laser which is made divergent by means of a lens can be reflected at a mirror in a way that two coherent light bundles arise. These two partial bundles superimpose and exhibit interference phenomena.

According to Fig. 1, a virtual image A' of the light source A is created at the mirror through the reflection of the laser light. The superposition of the direct and the reflected light leads to interferences on the translucent screen. Intensity maxima always occur at positions where the path difference Δs between the partial bundles from A and A' is an integer multiple of the wavelength λ . At great distances L , the following relation for the distance d between two neighbouring maxima (or minima) holds:

$$\lambda = \frac{a \cdot d}{L} \quad (I)$$

a : distance between the light sources A and A'

d : distance between two intensity maxima

L : distance between the screen and the light sources A or A'

λ : wavelength

The distance a between the light source A and the virtual light source A' is determined by means of a simple optical setup.

Fig. 1 Schematic representation of the beam path in Lloyd's mirror experiment

A: light source (He-Ne laser)

A' : virtual light source

a : distance between A and A'

L : distance between the screen and the light source A or A'

R: mirror

S: screen

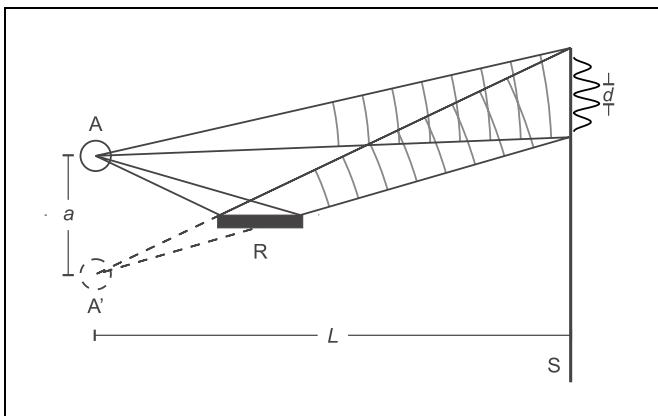

Fig. 2 Imaging the light sources A and A' by means of the lens H on the translucent screen

A: light source (He-Ne laser)

A' : virtual light source

H: imaging lens

a : distance between A and A'

B : distance between the light source images A and A' on the screen

g : object distance = distance of A and A' from the lens

b : image distance = distance of the lens H from the screen

R: mirror

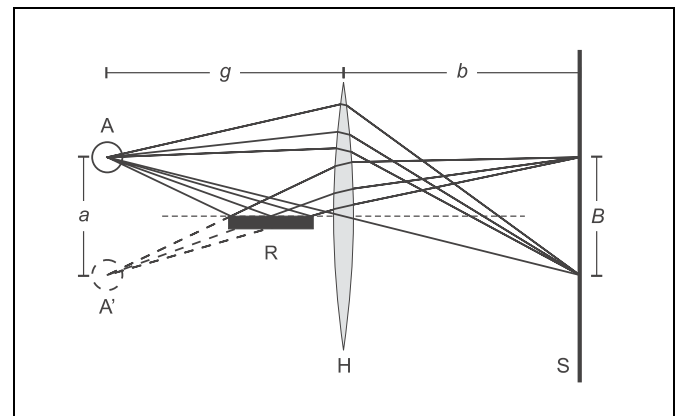

Apparatus

1 He-Ne laser, linearly polarized	471 830
1 Fresnel's mirror, adjustable	471 05
1 set of 50 microscope slides 76 mm × 26 mm	662 093
1 prism table	460 25
1 lens in frame, $f = +5$ mm	460 01
1 lens in frame, $f = +200$ mm	460 04
1 precision optical bench, 1 m	460 32
3 riders, $H = 60$ mm/ $B = 36$ mm	460 353
1 rider, $H = 60$ mm/ $B = 50$ mm	460 351
1 translucent screen	441 53
1 saddle base	300 11
1 vernier callipers	311 52
1 steel tape measure	311 77

For this the two light sources A and A' are sharply imaged on the screen S by means of a lens. From Fig. 2 the imaging equation can be read immediately:

$$\frac{a}{g} = \frac{B}{b} \quad \text{or} \quad a = \frac{B \cdot g}{b} \quad (\text{II})$$

a : distance between the light sources A and A'
 B : distance between the light sources A and A' on the screen
 g : object distance = distance of A and A' from the lens
 b : image distance = distance of the lens H from the screen

For the distance L the following relationship applies:

$$L = g + b \quad (\text{III})$$

If the focal length f of the imaging lens is known, the object distance g can be obtained with the aid of the imaging equation:

$$\frac{1}{g} = \frac{1}{f} - \frac{1}{b} \quad \text{or} \quad g = \frac{f \cdot b}{b - f} \quad (\text{IV})$$

From Eq. (II), (III) and (IV) the following relation for the wavelength λ is obtained:

$$\lambda = \frac{d}{L} \cdot \frac{f \cdot B}{b - f} = d \cdot \frac{f \cdot B}{b^2} \quad (\text{V})$$

Safety notes

The He-Ne laser meets the requirements according to class 2 of EN 60825–1 "Safety of laser equipment". If the corresponding notes of the instruction sheet are observed, experimenting with the He-Ne laser is safe.

- Never look into the direct or reflected laser beam.
- No observer must feel dazzled.

Setup

The entire setup is illustrated in Fig. 3. The spherical lens K with a focal length f of 5 mm expands the laser beam which then impinges on the mirror S in glancing incidence. The lens H is only placed in the beam path for determining the distance of the light sources A and A'.

- Using a rider, mount the He-Ne laser to the optical bench as shown in Fig. 3.
- Set up the screen at a distance of approx. 1.80 m from the laser.
- Direct the laser towards the screen, connect the plug-in power supply to the laser, and switch the laser on.
- Place the spherical lens with the focal length $f = +5$ mm on a rider at a distance of approx. 2 cm in front of the laser. The laser beam is expanded by the lens and should have a beam diameter of approx. 15 cm on the screen.
- Position the Fresnel mirror at a distance of approx. 15 mm in front of the spherical lens. Align the mirror as exactly as possible in parallel with the optical axis (for details see the instruction sheet of the Fresnel mirror).
- Incline the second partial mirror backwards by means of the knurled screw (**b**) (the laser beam must not graze the mirror). Now part of the laser beam's diameter is blocked out on the screen.
- Place the lens with the focal length $f = +200$ mm near the mirror as shown in Fig. 3, and move it towards the mirror.

On the screen two luminous spots should be seen (images of the light sources A and A') with a distance of approx. 8 mm in between them.

- Slightly turn the laser until the intensities of the two luminous spots A and A' are approximately equal.
- Remove the lens from the beam path, and move the mirror perpendicularly to the optical axis by means of the knurled screw (**a**) at the holder (this leads to the interference pattern on the screen being displaced).

Carrying out the experiment

It is recommendable to observe the interference phenomenon at first:

- For this move the mirror back and forth by means of the knurled screw (**a**).

Remark: This leads to the interference pattern being displaced on the screen; it must not be confused with a diffraction pattern, which may be present due to diffraction at the edge of the mirror holder.

- In order to determine the distance between the intensity maxima, put a sheet of paper on the screen and mark the locations of maximum light intensity (or, alternatively, minimum light intensity) using a soft pencil.
- Position the lens H ($f = +200$ mm) between the screen and the mirror as shown in Fig. 3, and create a sharp image of the light sources A and A'.
- Determine the distance B between the image of A and A'.
- Determine the image distance b .
- Using the vernier callipers, determine the distances between the intensity maxima marked on the sheet of paper, and calculate their mean value.

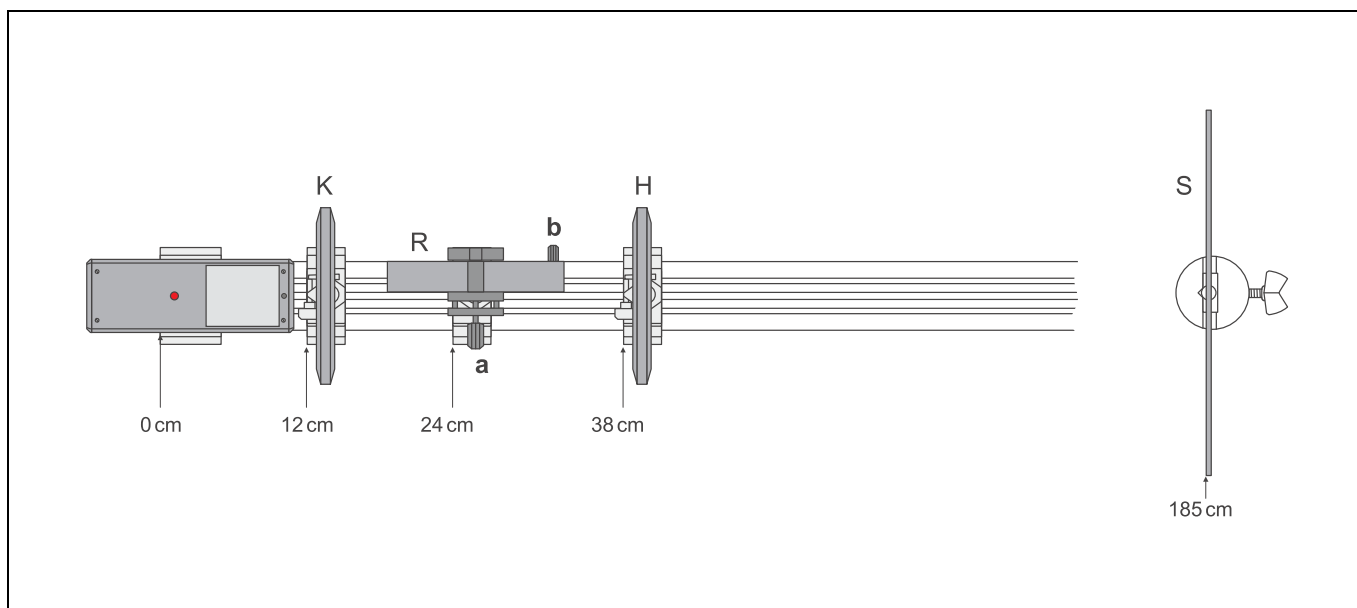

Fig. 3 Experimental setup for observing interference phenomena according to Lloyd's method (with the positions of the left edge of the optics riders given in cm).

K Lens for expanding the laser beam
 R mirror (Fresnel's mirror)
 H lens for imaging the light sources A and A' (Fig. 1)
 S screen

Evaluation

With the measured quantities

$$b = 146 \text{ cm}$$

$$d = 0.95 \text{ mm}$$

$$B = 7 \text{ mm}$$

and the focal length of the imaging lens

$$f = 20 \text{ cm},$$

Eq. (IV) leads to

$$g = 23 \text{ cm}.$$

With the aid of Eq. (V), the wavelength λ of the He-Ne laser can be determined:

$$\lambda = 624 \text{ nm}$$

Remark: nowadays there are more comfortable and much more precise methods of determining wavelengths.

From Eq. (III) the distance L between the screen and the light sources A or A' results to $L = 169 \text{ cm}$. This means, the idealized source of light A lies in beam direction somewhat behind the spherical lens K.

Measuring example

Table 1: Distances d between the intensity maxima

Measured value	$\frac{d}{\text{mm}}$
1	1.00
2	0.95
3	0.95
4	0.95
5	0.90

Mean value $d = 0.95 \text{ mm}$

Image distance: $b = 146 \text{ cm}$

Distance between the images A and A': $B = 7 \text{ mm}$

Result

Reflection of the light at a mirror makes it possible to create a second light source which is coherent with respect to the first one. The superposition of the direct and the reflected light bundle leads to an interference pattern.

Supplementary information

The relation between the wavelength and the geometrical quantities in Lloyd's mirror experiment – i.e. Eq. (I) – corresponds to the relation which describes the interference behind a double slit (Young's two-slit experiment).

