

## Operating the hot-air engine as a heat pump and a refrigerating machine

### Objects of the experiments

- Operating the hot-air engine as a heat pump by driving the flywheel anti-clockwise.
- Determining the maximum temperature in the cylinder head.
- Operating the hot-air engine as a refrigerating machine by driving the flywheel clockwise.
- Determining the minimum temperature in the cylinder head.

Fig. 1 Diagram illustrating the principle of operation of a hot-air engine as a heat pump (above) and as a refrigerator (below)

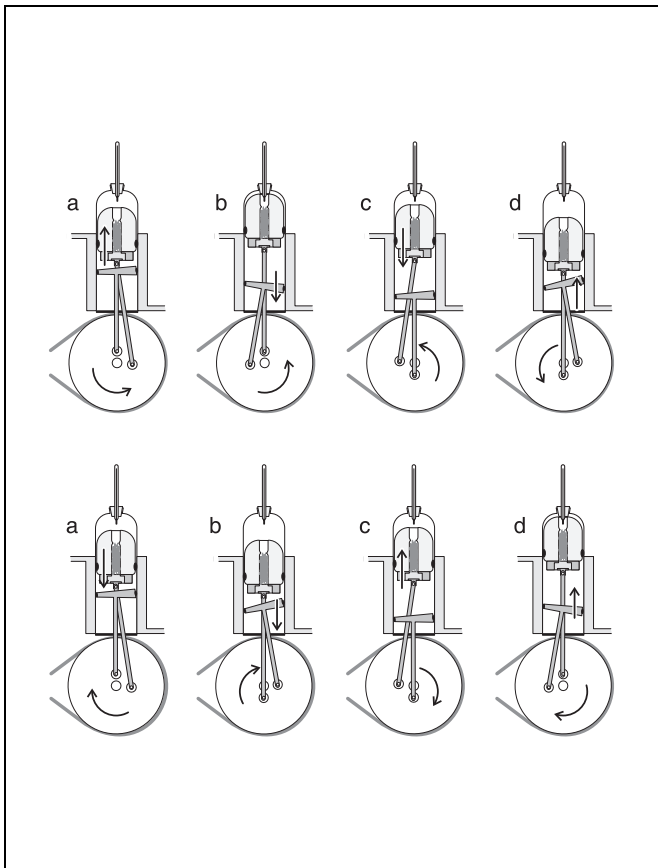

### Principles

The hot-air engine (*R. Stirling*, 1816) works as a heat pump or as a refrigerator when its flywheel is driven from outside. The displacement piston and the working piston are connected to the crankshaft via piston rods so that they run with a phase difference of  $90^\circ$ . If the flywheel is rotated anti-clockwise, the displacement piston moves upwards while the working piston is at top dead centre, and it displaces the air into the lower part of the cylinder which is water-cooled (see Fig. 1 above). After this, the air in the lower part is expanded by the working piston and absorbs heat from the "cooling water". While the working piston is in the lower dead centre, the displacement piston moves downwards and displaces the air into the upper part of the cylinder. There the air is compressed by the working cylinder and gives off heat to the cylinder head; that is, the hot-air engine works as a heat pump.

If the flywheel is rotated clockwise, the displacement piston displaces the air upwards, while the working piston is in the upper dead centre (see Fig. 1 below). Therefore, heat is extracted from the cylinder head during the subsequent expansion of the air by the working piston. The air is then displaced downwards by the displacement piston and, in the lower part, compressed by the working piston. Therefore it gives off heat to the cooling water; that is, the hot-air engine works as a refrigerator.

In the experiment, the operation of the hot-air engine as a heat pump and as a refrigerator is studied qualitatively. The relation between the mechanical power supplied and the heating (cooling) power is demonstrated by varying the speed of the driving electric motor with the control unit and measuring the change of temperature in the cylinder head with a thermometer.

**Apparatus**

1 hot-air engine . . . . .	388 182
1 thermometer, -50 °C to 120 °C . . . . .	38819
1 experiment motor . . . . .	347 35
1 control unit for experiment motor . . . . .	347 36
1 stand rod 25 cm . . . . .	300 41

*additionally required:*

open water vessel (10 l at least)	
1 submersible pump 12 V . . . . .	388 181
1 low-voltage power supply . . . . .	522 16
2 silicone tubings, int. dia. 7 × 1.5 mm, 1 m	667 194

or  
a tap with running water and runoff

**Setup**

The experimental setup is illustrated in Fig. 2.

**Cooling-water supply:**

- Fill at least 10 l of water into the open water vessel, and hang the submersible pump in.
- Connect the output of the submersible pump to the cooling-water inflow of the hot-air engine, and guide the cooling water drain into the water vessel.
- Connect the submersible pump to the low-voltage power supply.

or

- Connect the cooling-water inflow of the hot-air engine to the tap, and guide the cooling-water drain to the runoff.

**Temperature measurement:**

- Mount the cylinder-head cap with screw closure (see instruction sheet of the hot-air engine), and unscrew the screw closure.
- Put the thermometer through the screw closure and the packing ring.
- Drive the displacement piston to the upper dead centre by turning the flywheel, and check whether the displacement piston touches the thermometer.
- Clamp the thermometer by fastening the screw closure.

Fig. 2 Experimental setup for operating the hot-air engine as a heat pump and refrigerator (shown here: cooling-water supply from the water vessel by means of the submersible pump).

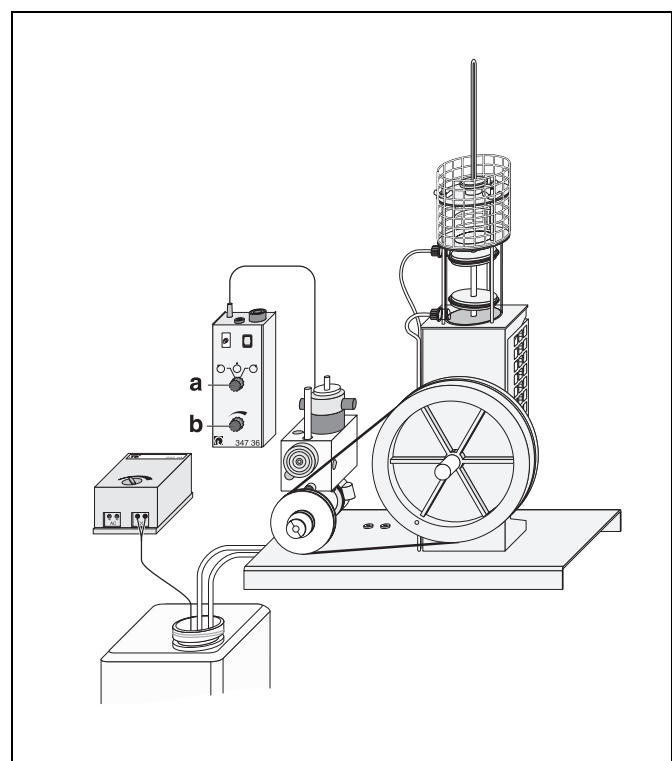

**Safety notes**

Do not expose the glass components of the hot-air engine to excess thermal load.

- Mind the instruction sheet of the hot-air engine.
- Do not operate the hot-air engine without cooling water. Make sure that the circulation of the cooling water is flawless.
- Do not allow the temperature of the cooling water to exceed 30 °C when the water enters the cooling circuit.

Remark:

*During operation of the hot-air engine an excess pressure is generated and the thermometer may be catapulted upwards.*

- Turn the flywheel, and check the packing of the hot-air engine; if necessary, close the tubing shaft for the pressure sensor with a stopper.

Drive:

- Mount the electric motor, and connect it to the control unit.
- Lay the driving belt around the flywheel and around the driving disc, and tighten it by swivelling the electric motor.

## Carrying out the experiment

### a) Operating the hot-air engine as a heat pump:

- Switch the cooling-water supply on (set, for example, the low-voltage power supply for the submersible pump to step 2), check the flow, and wait until the water returns through the outlet tubing.
- Set the rotation switch **(a)** to the middle position (standstill), set the speed controller **(b)** to the middle position, and switch the control unit on.
- Start the hot-air engine with the rotation switch so that it runs to the left (anti-clockwise).
- Measure the temperature in the cylinder head, and observe the increase of the temperature.
- If necessary, increase the speed slowly with the speed controller.

–When the temperature has reached its maximum value, reset the rotation switch to the middle position.

### b) Operating the hot-air engine as a refrigerator:

- Start the hot-air engine with the rotation switch so that it runs to the right (clockwise).
- Measure the temperature in the cylinder head, and observe the decrease of the temperature.
- If necessary, increase the speed slowly with the speed controller.
- When the temperature has reached its minimum value, reset the rotation switch to the middle position.

## Measuring example

### a) Operating the hot-air engine as a heat pump:

maximum temperature after a long interval of operation: 110 °C.

### b) Operating the hot-air engine as a refrigerator:

minimum temperature after a long interval of operation: –32 °C.

## Evaluation

Depending on the direction of rotation, heat is transferred to the cylinder head or extracted from it. The temperature in the cylinder head changes until the temperature of equilibrium has turned up, that is, until the rate of heat transferred to the surroundings equals the rate of heat extracted from the surroundings.

## Results

When mechanical work is put into the hot-air engine via its flywheel, the cylinder head can, depending on the sense of rotation, absorb or give off heat. At the same time heat is extracted from the cooling water or transferred to it.

The hot-air engine works as a heat pump when the flywheel is rotated anti-clockwise and as a refrigerator when the flywheel is rotated clockwise.

## Supplementary information

An impressive demonstration of the hot-air engine operated as a heat pump or as a refrigerator can be achieved by replacing the thermometer in the cylinder head with a test tube (from the scope of supply of the hot-air engine) and filling the test tube with 0.5–1 cm<sup>3</sup> of distilled water. After some minutes the water begins to boil or to freeze.

The demonstration is particularly impressive, if the temperature is measured with a temperature sensor and recorded as a function of time. Then a delay in freezing is observed, because the water is first cooled considerably below 0 °C, and then it freezes all of a sudden at 0 °C.

