

## Operating a hot-air engine as a heat engine

### Objects of the experiments

- Starting the hot-air engine as a heat engine by heating the cylinder electrically.
- Studying qualitatively the dependence of the idling speed on the heating current.
- Studying qualitatively the dependence of the speed on the retarding force (frictional force).

### Principles

The hot-air engine (*R. Stirling*, 1816) is, apart from the steam engine, the oldest heat engine. Its principle of operation is illustrated schematically in Fig. 1. In the hot-air engine two pistons are connected to a crankshaft via piston rods. The displacement piston runs ahead of the working piston by  $90^\circ$ . When the working piston is at top dead centre (**a**), the displacement piston moves downwards and displaces the air upwards into the heated part of the cylinder. The air is heated, expands and drives the working piston downwards (**b**). While this happens, mechanical work is transferred to the flywheel. When the working piston is in the lower dead centre (**c**), the displacement piston moves upwards and displaces the air downwards into the cooled part of the cylinder. The air is cooled and compressed by the working piston (**d**). The mechanical work necessary for the compression is provided by the flywheel.

The fractions of air above and below the displacement piston are connected via an axial bore in the displacement piston. While the hot air is displaced downwards, it transfers its heat to a copper-wool fill in the bore. When, after this, the air is

displaced upwards, it reabsorbs heat from the copper wool. The copper wool thus serves as a regenerator.

In an oversimplified picture, the air is heated and cooled at a constant volume, whereas it is expanded and compressed at a constant temperature. The thermodynamic cycle of the hot-air engine has, therefore, the following stages: isochoric heat input (**a**), isothermal expansion at high temperature (**b**), isochoric heat output (**c**) and isothermal compression at low temperature (**d**). This idealized process (see Fig. 2) is generally called Stirling cycle.

In the experiment, the operation of the hot-air engine as a heat engine is studied qualitatively. The relation between the thermal power put in electrically and the mechanical power output is demonstrated by varying the voltage at the filament. The idling speed in the various cases is a measure for the mechanical power output. A copper rope wound around the shaft of the flywheel can enhance the frictional force and thus retard the engine to a lower speed.

Fig. 1 Diagram illustrating the principle of operation of a hot-air engine as a heat engine

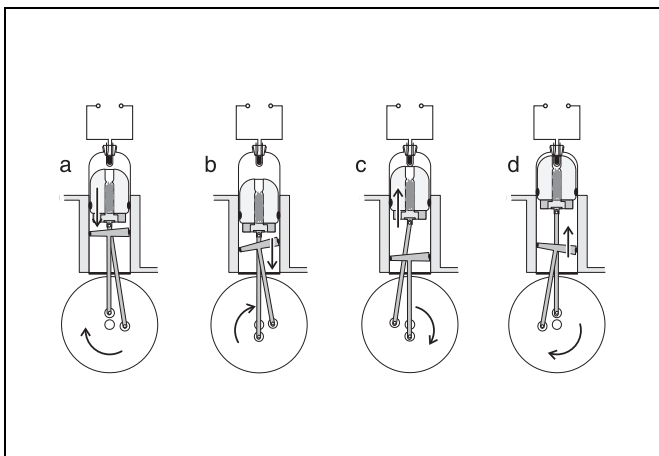
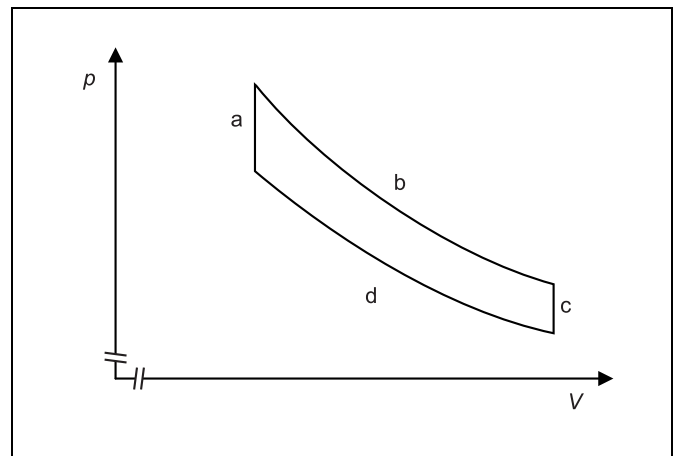

Fig. 2 Stirling cycle: idealized pressure volume diagram of the hot-air engine



**Apparatus**

|   |         |
|---|---------|
| 1 hot-air engine . . . . .                    | 388 182 |
| 1 U-core with yoke . . . . .                  | 562 11  |
| 1 clamping device . . . . .                   | 562 12  |
| 1 mains coil, 230 V, with 500 turns . . . . . | 562 21  |
| 1 extra-low-voltage coil, 50 turns . . . . .  | 562 18  |

connection leads, 2.5 mm<sup>2</sup> cross section

*additionally required:*

|   |         |
|---|---------|
| open water vessel (10 l at least)               |         |
| 1 submersible pump 12 V . . . . .               | 388 181 |
| 1 low-voltage power supply . . . . .            | 522 16  |
| 2 silicone tubings, int. dia. 0.7 × 1.5 mm, 1 m | 667 194 |

or

a tap with running water and runoff

**Safety notes**

When the hot-air engine is operated as a heat engine, it is not self-starting. It stops, for example, after a power failure. Blocking the piston rods and the crankshaft, too, can cause a standstill of the engine. In case of a standstill, the heat supplied to the cylinder is not dissipated at a sufficient rate.

- Mind the instruction sheet of the hot-air engine.
- Do not heat the cylinder head continuously when the engine lies idle.
- Do not leave the hot-air engine unsupervised.
- In case of a standstill, switch the heating off immediately.
- Protect the piston rods and the crankshaft against unauthorized access by putting on the grille.

Do not expose the glass components of the hot-air engine to excess thermal load.

- Do not operate the hot-air engine without cooling water. Make sure that the circulation of the cooling water is flawless.
- Do not allow the temperature of the cooling water to exceed 30 °C when the water enters the cooling circuit.
- Heat the filament up to high temperatures (yellow heat) only when the engine runs fast, and do not maintain high temperatures in continuous operation.

Attention: The cylinder-head cap and the connector sockets become very hot during longer intervals of operation at maximum calorific power.

- Mount the grille of the cylinder.
- Allow the hot-air engine to cool down before removing the connecting cables or before exchanging the cylinder-head cap.

**Setup**

The experimental setup is illustrated in Fig. 3.

**Cooling-water supply:**

- Fill at least 10 l of water into the open water vessel, and hang the submersible pump in.
- Connect the output of the submersible pump to the cooling-water inflow of the hot-air engine, and guide the cooling water drain into the water vessel.
- Connect the submersible pump to the low-voltage power supply.

or

- Connect the cooling-water inflow of the hot-air engine to the tap, and guide the cooling-water drain to the runoff.

**Voltage supply:**

- Mount the cylinder-head cap with filament (mind the marks, see instruction sheet of the hot-air engine).
- Turn the flywheel, and check the packing of the hot-air engine; if necessary, close the tubing shaft for the pressure sensor with a stopper.
- Set the demountable transformer up and connect the 12-V output to the connector sockets of the cylinder-head cap.

**Carrying out the experiment****Operating the hot-air engine as a heat engine:**

- Switch the cooling-water supply on (set, for example, the low-voltage power supply for the submersible pump to step 2), check the flow, and wait until the water returns through the outlet tubing.
- Tap a heating voltage of 12 V, switch the mains coil on, and observe the filament.

As soon as the filament is red-hot:

- Start the hot-air engine up by turning the flywheel clockwise.

If the hot-air engine does not start despite several trials:

- Switch the mains coil off, and check the setup.

**Varying the heating voltage:**

- Reduce the heating voltage to 6 V and enhance it to 20 V step by step while the engine is running; after every change wait some minutes, and observe the idling speed.

**Varying the retarding force:**

- Tap a heating voltage of 12 V.
- Wind the copper rope around the shaft in the sense of rotation, and retard the engine to half the idling speed by carefully pulling the copper rope.

*Remark:*

*The mechanical load must not cause the engine to stop. The speed should, therefore, not fall below half the idling speed. If the engine still comes to a standstill:*

*Immediately start the engine up again, or switch the heating off.*

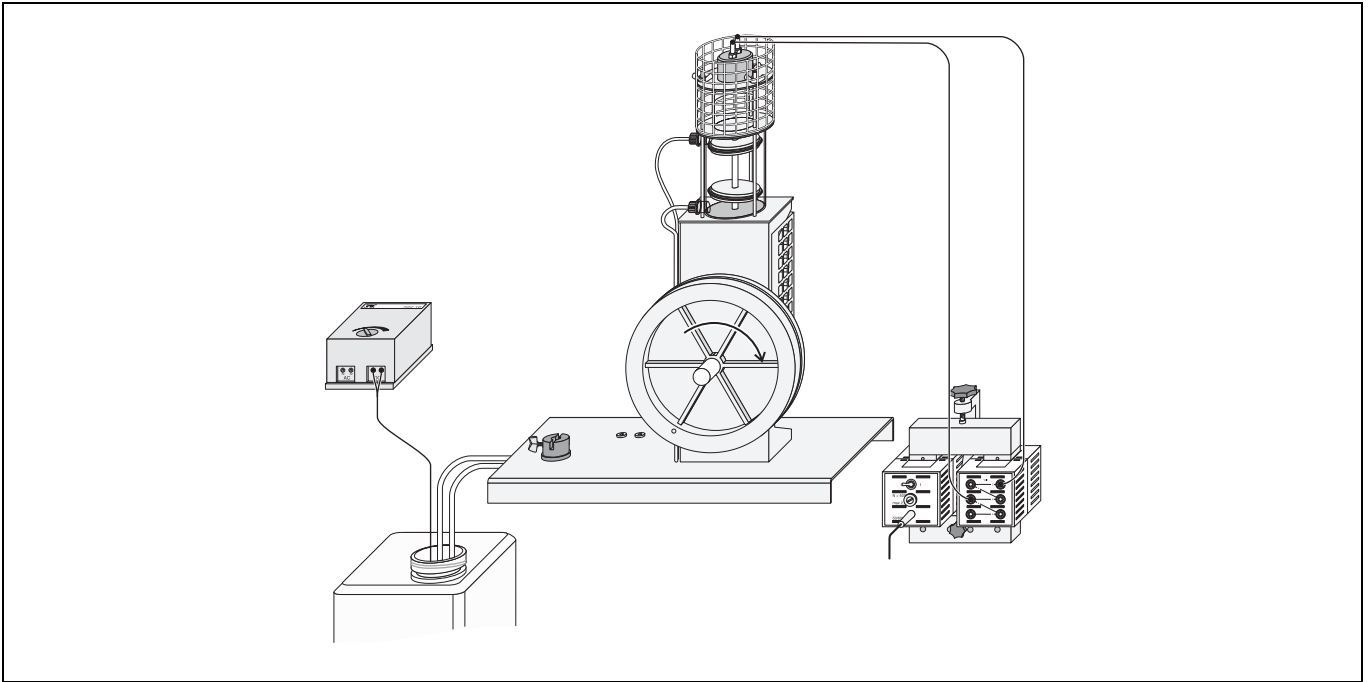

Fig. 3 Experimental setup for operating the hot-air engine as a heat engine (shown here: cooling-water supply from the water vessel by means of the submersible pump).

## Measuring example and evaluation

### Varying the heating voltage:

The heating voltage can be varied between 6 V and 20 V while the engine is running. With increasing heating voltage, the idling speed increases considerably:

When the heating voltage is increased, more thermal power is put into the hot-air engine. The engine can give off more mechanical power and, therefore, reaches a higher idling speed.

### Varying the retarding force:

With increasing tensile force on the copper rope wound around the shaft, the speed decreases:

The machine is retarded to a lower speed by a higher frictional force. When the machine is retarded, it gives off mechanical power, which is not made use of but which is transformed into frictional heat.

## Result

If heat is applied at the cylinder head of the hot-air engine, mechanical power can be picked up at the shaft. At the same time a part of the heat is educed to the cooling water. The hot-air engine works as a heat engine.

