

Confirming Archimedes' principle

Objects of the experiments

- Observing the buoyancy force acting on a cylinder immersed in a liquid.
- Experimental comparison of the buoyancy force and the weight of the displaced liquid.

Principles

Archimedes' principle is experimentally verified in the experiment. This principle states that a body immersed in a liquid is acted upon by a buoyancy force F , the magnitude of which is equal to the weight G of the displaced liquid.

In order to verify Archimedes' principle, a hollow cylinder and a solid cylinder which fits exactly into the hollow cylinder hang, one below the other, at the beam of a hydrostatic balance. The deflection of the balance is adjusted to zero. When the solid cylinder is immersed in a liquid, the balance clearly shows an apparent reduction in weight. A buoyancy force acts opposite to the force of gravity. The deflection of the balance can be readjusted to zero by filling the same liquid into the hollow cylinder so that the weight of the liquid in the hollow cylinder compensates the buoyancy force.

Setup

The experimental setup is illustrated in Fig. 1.

- Set up the hydrostatic balance at a site that is as free as possible from shock, thermal radiation and air current.
- If necessary, clean the edges and the bearing with a clean cloth and alcohol or benzine.
- Suspend a long stirrup from the right suspension hook and the short stirrup from the left suspension hook. Place the balance pans on the pan holders.
- Slide the balance beam on the holder with scale to the top.
- Adjust the balance using the tare nuts of the balance beam.

If the range is not sufficient:

- Exchange the balance pans and the stirrups.

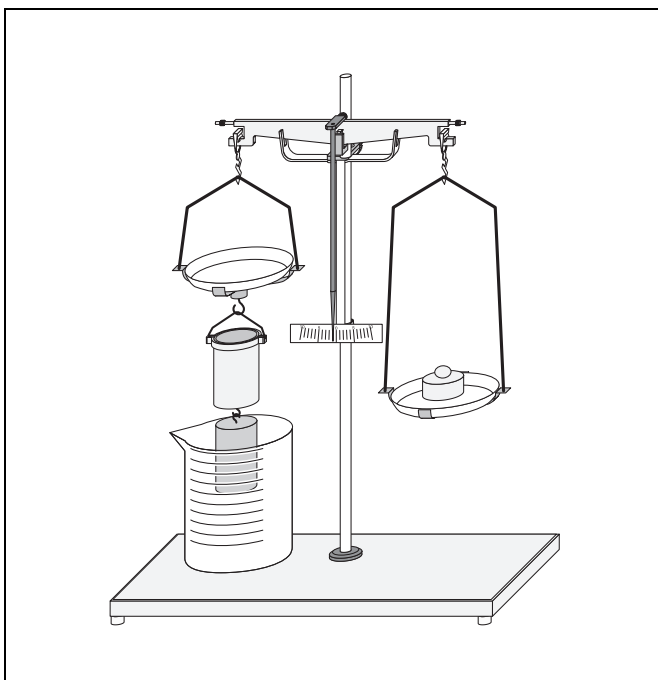

Fig. 1 Experimental setup for the confirmation of Archimedes' principle

Apparatus

1 Archimedes cylinder	362 01
1 hydrostatic precision balance, 200 g . . .	315 01
1 set of weights, 10 mg – 200 g	315 31
1 beaker, 100 ml, ts, hard glass	664 111
1 beaker, 250 ml, ts, hard glass	664 113
Glycerine, 99 %, 250 ml	672 121
Ethanol, denaturated, 1l	671 972

in addition:

Distilled water, 250 ml

Carrying out the experiment

Note: At a weight of 200 g, a deflection by one scale mark corresponds to a mass difference of about 100 mg.

- Suspend the hollow cylinder and the solid cylinder, one below the other, from the short stirrup and readjust the balance by putting weights on the right balance pan.
- Fill about 175 ml of distilled water into the large beaker, and place the beaker below the solid cylinder.
- Slowly slide the balance beam on the holder with scale downwards until the solid cylinder is completely immersed in the liquid; thereby observe the deflection of the balance from the moment when the solid cylinder touches the liquid.
- Fill distilled water into the hollow cylinder up to the brim, and observe the deflection of the balance.
- Remove drops of the liquid from the outer wall using, for example, a piece of absorbent tissue.
- Adjust the height of the balance beam on the holder with scale so that the solid cylinder is just immersed without resting on the bottom of the beaker.

Note: The surface tension of the liquid causes an additional distorting force on the solid cylinder.

- Pour the distilled water out, and dry the beaker, the hollow cylinder and the solid cylinder using, for example, absorbent tissue.
- Repeat the experiment with ethanol and glycerine.

Measuring example and evaluation

Mass of the solid and the hollow cylinder together: 200.62 g

As soon as the solid cylinder is immersed in the liquid, the pointer is deflected to the left. The solid cylinder apparently loses weight. A buoyancy force opposite to the force of gravity acts on the cylinder.

With growing depth of immersion the deflection of the pointer increases until the balance beam stops at the holder.

When the same liquid is filled into the hollow cylinder, the deflection decreases and becomes zero as soon as the hollow cylinder is filled up so that the weight of the liquid in the hollow cylinder compensates the buoyancy force on the solid cylinder.

Results

A buoyancy force acts on a body immersed in any liquid.

The buoyancy force is equal to the weight of the displaced liquid (Archimedes' principle).