

Acoustic beats

Displaying on the oscilloscope

Objects of the experiments

- Studying acoustic beats resulting from the superposition of tuning-fork oscillations with slightly different frequencies.
- Displaying the beats on the oscilloscope
- Determining the beat frequency f_b and the frequency f of the superposed oscillation and comparing these frequencies with the individual frequencies f_1 and f_2 .

Principles

The wave character of sound becomes obvious when the superposition of two sound waves with equal amplitudes A_1 and A_2 and slightly different frequencies f_1 and f_2 is studied. At the position of the observer an oscillation comes about with the time dependence

$$y(t) = A_1 \cdot \cos(2\pi \cdot f_1 \cdot t + \varphi_1) + A_2 \cdot \cos(2\pi \cdot f_2 \cdot t + \varphi_2) \quad (I).$$

The fact that the phases φ_1 and φ_2 of the two individual oscillations are completely arbitrary has been taken into account.

In order to calculate the beat signal, the quantities

$$A = \frac{A_1 + A_2}{2}, \bar{A} = \frac{A_1 - A_2}{2}, f = \frac{f_1 + f_2}{2}, \bar{f} = \frac{f_1 - f_2}{2},$$

$$\varphi = \frac{\varphi_1 + \varphi_2}{2} \text{ und } \bar{\varphi} = \frac{\varphi_1 - \varphi_2}{2}$$

are introduced. After some transformations, the superposed signal is given by

$$y(t) = 2 \cdot A \cdot \cos(2\pi \cdot \bar{f} \cdot t + \bar{\varphi}) \cdot \cos(2\pi \cdot f \cdot t + \varphi) - 2 \cdot \bar{A} \cdot \sin(2\pi \cdot \bar{f} \cdot t + \bar{\varphi}) \cdot \sin(2\pi \cdot f \cdot t + \varphi) \quad (II)$$

This expression becomes even simpler,

$$y(t) = 2 \cdot A \cdot \cos(2\pi \cdot \bar{f} \cdot t + \bar{\varphi}) \cdot \cos(2\pi \cdot f \cdot t + \varphi) \quad (III),$$

if the two amplitudes A_1 and A_2 agree exactly. In this case, $y(t)$ can be regarded as an oscillation with the frequency f and a time dependent amplitude:

$$y(t) = a(t) \cdot \cos(2\pi \cdot f \cdot t + \varphi) \quad (IV)$$

with

$$a(t) = 2 \cdot A \cdot \cos(2\pi \cdot \bar{f} \cdot t + \bar{\varphi}) \quad (V).$$

The magnitude of the amplitude a varies periodically between 0 and $2A$ (see Fig. 1), the change occurring twice during one period. The number of so-called beats per second, the beat frequency f_b , is therefore

$$f_b = 2 \cdot \bar{f} = f_1 - f_2 \quad (VI).$$

When the amplitude $a(t)$ passes zero, the sign change of the beat leads to a phase jump in the superposed oscillation.

In this experiment, the superposition of two sound waves generated with tuning-forks that are slightly out of tune is studied. The beat signal is received with a microphone and then displayed on an oscilloscope. By detuning one tuning-fork the beat frequency f_b is enhanced, or, in other words, the beat period

$$T_b = \frac{1}{f_b} \quad (VII)$$

is made shorter. The frequencies f_1 , f_2 , and f_b are determined by measuring the corresponding periods T_1 , T_2 , and T_b with the oscilloscope.

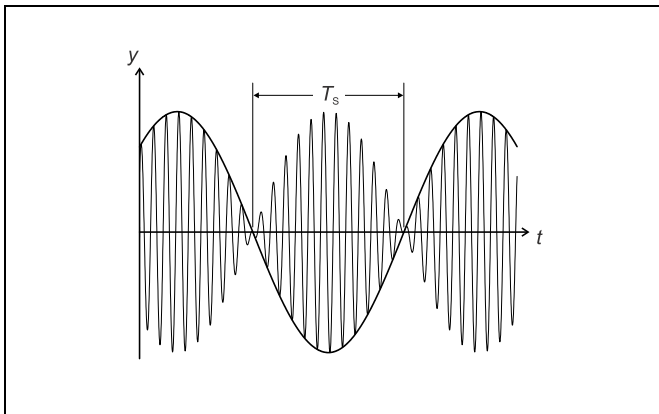

Fig. 1 Acoustic beats when the individual oscillations have the equal amplitudes.

Apparatus

1 pair of resonance tuning-forks, 440 Hz	414 72
1 multi-purpose microphone	586 26
1 saddle base	300 11
1 two-channel oscilloscope 303	575 21
1 BNC/ 4 mm adapter, 2-pole	575 35

Carrying out the experiment

- Strike the two tuning-forks with the hammer one immediately after the other, and compare the audible beats with the display on the oscilloscope.
- Determine the beat period T_b , and record it.
- Set the time base to 0.5 ms/DIV.
- In order to determine the periods T_1 and T_2 , strike each tuning-fork separately while the other is removed from the resonance box.

Setup

The experimental setup is illustrated in Fig. 2.

- Set the switch **(a)** of the multi-purpose microphone to ~ .
- Lower the frequency of one tuning-fork by means of the clamping screw **(b)**.
- Put the tuning-forks on the resonance boxes, and direct the openings of the boxes towards the microphone.
- Connect the multi-purpose microphone to the oscilloscope via the BNC/4 mm adapter:

Zero line: middle
 Coupling: AC
 Scan: 20 mV/DIV.
 Trigger: Auto
 Time base: 20 ms/DIV.

Measuring example

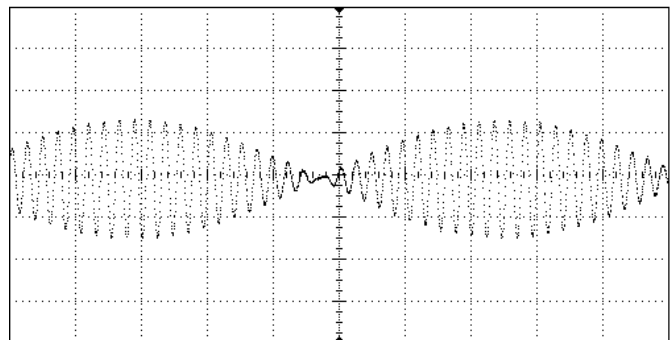
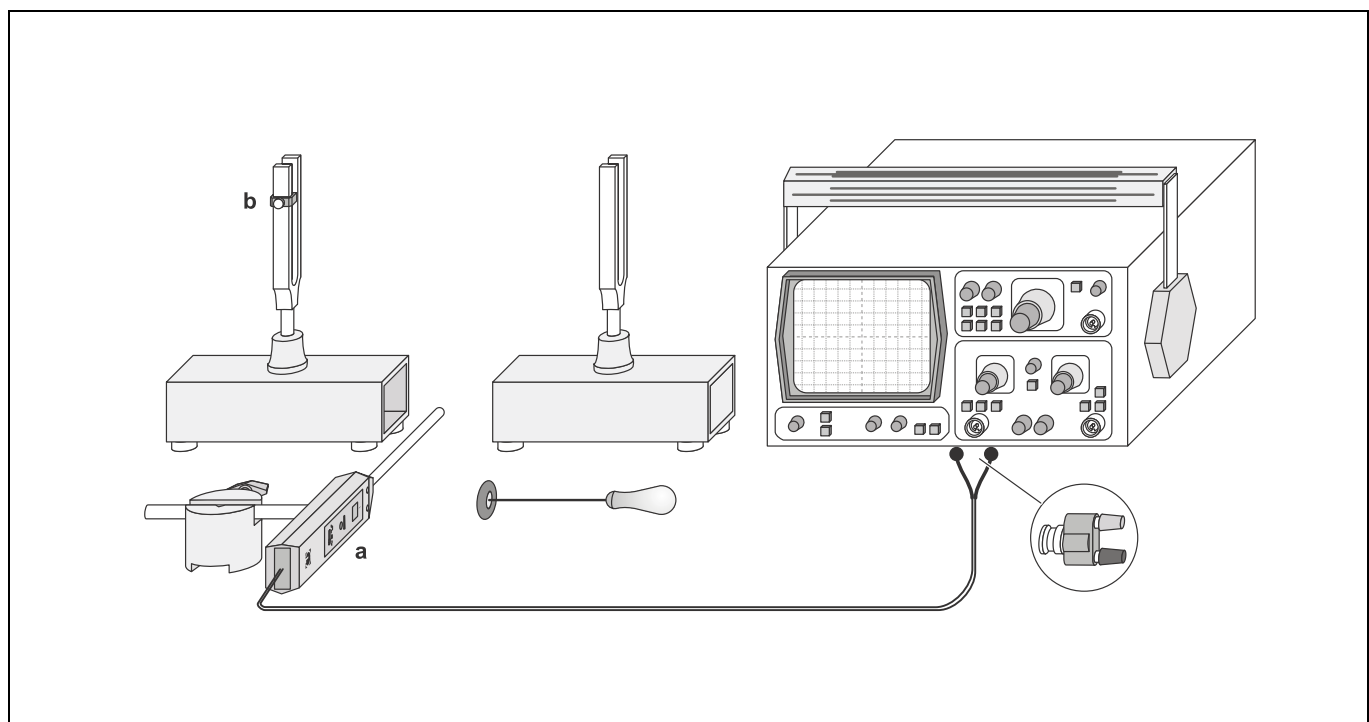

Fig. 3 Experimental setup for displaying acoustic beats on the oscilloscope

Table 1: The individual periods T_1 and T_2 and the beat period T_b :

$\frac{T_1}{\text{ms}}$	$\frac{T_2}{\text{ms}}$	$\frac{T_b}{\text{ms}}$
2.20	2.25	112

Fig. 2 Display of an acoustic beat on the oscilloscope



Evaluation

Table 2: The individual frequencies f_1 and f_2 and the beat frequency f_b

$\frac{f}{\text{Hz}}$	$\frac{f}{\text{Hz}}$	$\frac{f_s}{\text{Hz}}$	$\frac{f_1 - f_2}{\text{Hz}}$
455	444	9	11

Eq. (VI) is confirmed by comparing the measured beat frequency f_b with the difference $f_1 - f_2$.

Results

When two acoustic oscillations with a slight difference in frequency are superposed, beats that are clearly audible are generated. These beats can be displayed on an oscilloscope.

Supplementary information

More precise investigations are possible if the beats are recorded with a storage oscilloscope or with the computer-assisted data logging system CASSY.

