

Refraction of water waves

Objects of the experiment

- Observing the change in the direction of propagation of straight water waves at the transition between two different water depths (at a plane-parallel body).
- Comparing the change in the directions of propagation and the wavelengths of water waves at the transition between two different water depths and confirmation of the law of refraction.
- Observing the refraction of water waves at a prism (straight boundaries).
- Observing the refraction of water waves at a biconvex lens (curved boundaries).
- Observing the refraction of water waves at a biconcave lens (curved boundaries).

Principles

As long as the water depth is not significantly greater than the wavelength, the wave velocity increases with the water depth. In the case of straight waves, the direction of propagation changes with the wave velocity at the transition from one depth to the next. This is known as refraction, and the law of refraction applies (cf. Fig. 7).

$$\frac{\sin \alpha}{\sin \beta} = \frac{\lambda_1}{\lambda_2}$$

(α : angle of incidence, β : angle of refraction ,
 λ_1 : wavelength in zone 1, λ_2 : wavelength in zone 2)

A plane-parallel plate is placed in the filled wave trough to permit observation. This creates zones of different water depths, and thus different wave velocities.

Practical applications for refraction of waves include the construction of a prism for deflection, a biconvex lens for focusing or a biconcave lens for scattering the wave "beam".

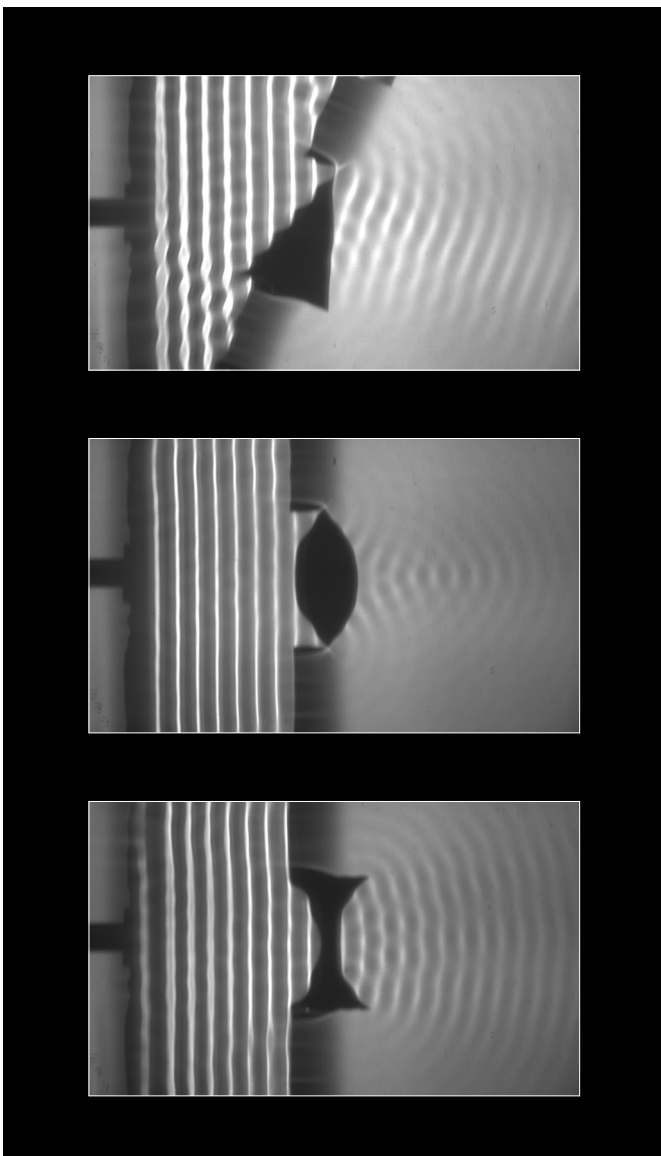

Fig. 1 Refraction of water waves (photographs)
Top: refraction of water waves at a prism
Middle: convergent wave paths behind a biconvex lens
Bottom: divergent wave paths behind a biconcave lens

Apparatus

1 Wave trough with motor stroboscope 401 501

additionally required:

Dish soap,
transparencies, transparency pens, adhesive tape,
ruler, protractor

Setup

Set up the experiment as shown in Fig. 2.

- Set up the wave trough so that it is not subject to shocks and vibrations; observe all information given in the Instruction Sheet. Use a spirit level and make sure that the glass plate is aligned precisely horizontally. Do not yet fill the wave trough with water.
- Place the plane-parallel plate of transparent acrylic glass in the wave trough (see Fig. 3). Carefully pour water into the trough until the water level is approx. 1 mm over the plate.
- Connect the exciter for straight waves and place it in front of the plane-parallel plate (see Fig. 3).
- Attach a transparency to the observation screen **(g)** using adhesive tape.

Carrying out the experiment**a) Refraction of water waves at the edges of the plane-parallel plate:**

- If necessary, rotate the stroboscope disk out of the beam path using knurled screw **(f)** so that the glass pane in the bottom of the wave trough is completely illuminated.
- Using knob **(e)**, set a frequency of approx. 20 Hz, and carefully increase the excitation amplitude using knob **(d)** until wave fronts are clearly visible (see Instruction Sheet for wave trough).
- Vary the immersion depth of the exciter as necessary with adjusting screw **(h)**.
- Vary the water depth if no easily visible straight waves are generated at the plane-parallel plate.
- Compare the directions of propagation and the wavelengths in front of and over the plane-parallel plate.
- To quantitatively compare the directions of propagation and the wavelengths, switch on the stroboscope with switch **(a)**; after a short warm-up time, you may need to carry out a fine adjustment of the excitation and stroboscope frequencies using knob **(b)** until a stationary wave image appears.
- Sketch the edges of the plane-parallel plate, the direction of propagation of the water waves in front of and above the plate and the spacing of the wave fronts on the transparency.
- Draw in the wave axis (“axis of incidence”) and measure the angle of incidence and refractive angle.
- Measure the wavelength in both zones. To do this, measure the distance between two wave fronts on the observation screen. Be sure to take the image scale into consideration to determine the actual wavelength (see Instruction Sheet for wave trough).
- Compare the angle of incidence and refractive angle with the respective wavelengths (see table 1).
- Set different excitation frequencies between 10 Hz and 30 Hz. Measure and compare the directions of propagation and the wavelengths as described above.
- Vary the direction of the incident waves by changing the position of the plane-parallel plate or the wave exciter and measure and compare the directions of propagation and the wavelengths as described above.
- Using knob **(d)**, increase the amplitude until waves become visible behind the plate as well. Compare the direction of the twice-refracted wave with the original direction of the wave.
- Repeat the experiment with a wave packet. If necessary, rotate the stroboscope disk out of the beam path, turn amplitude knob **(d)** all the way to the left and press pushbutton **(c)** for single-wave excitation.

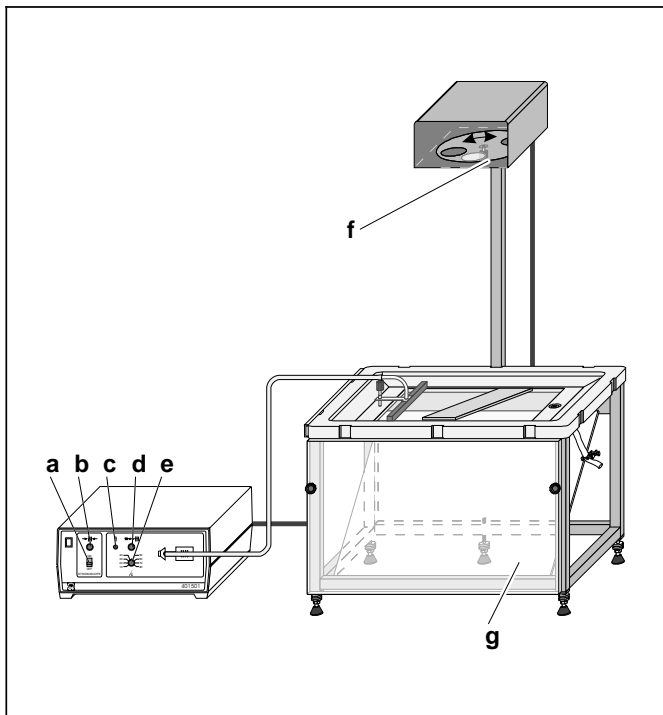

b) Refracting water waves at a prism:

- Remove the plane-parallel plate and place the prism in the middle of the wave trough as shown in Fig. 4. Place the obstacle with large slit on top of the prism. Cover the short side of the prism with the wide cover slide. Attach a transparency to observation screen (g).
- If necessary, rotate the stroboscope disk out of the beam path so that the glass pane in the bottom of the wave trough is completely illuminated.
- Use the exciter to generate straight waves. Set a frequency of approx. 20 Hz, and carefully increase the excitation amplitude until the waves behind the prism are clearly visible. You may need to correct the water level.
- Compare the direction of propagation behind the prism with the original direction. If necessary, change the angle of incidence by turning the prism.
- Sketch the edges of the prism and the directions of propagation on the transparency.

c) Refraction of water waves at a biconvex lens and a biconcave lens:

- Take out the prism, lay the obstacle with large slit in the middle of the wave tank and place the plastic biconvex lens in the slit.
- If necessary, rotate the stroboscope disk out of the beam path so that the glass pane in the bottom of the wave trough is completely illuminated.
- Set a frequency of approx. 20 Hz, and carefully increase the excitation amplitude until the waves behind the lens are clearly visible. You may need to correct the water level.
- Compare the directions of propagation in front of and behind the lens.
- Using the stroboscope, generate a standing wave image.
- Set different excitation frequencies between 10 Hz and 80 Hz. Adjust the exciter amplitude where necessary. Compare the directions of propagation as described above.
- Repeat the experiment with a wave packet.
- Observe the refraction of water waves at various depths. Add water, set a frequency of approx. 20 Hz, and carefully reduce the water depth by draining the water. Observe the wave image.
- Replace the biconvex lens with the biconcave lens and repeat the above experiment steps.

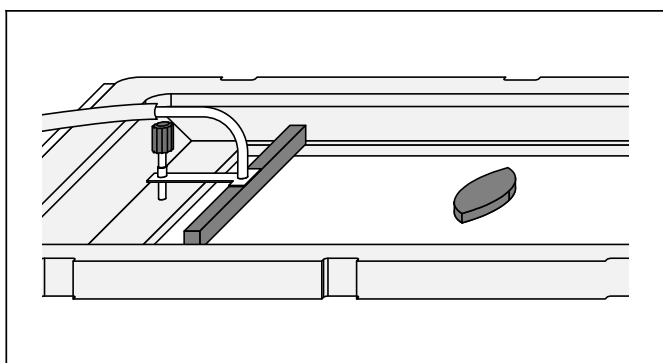
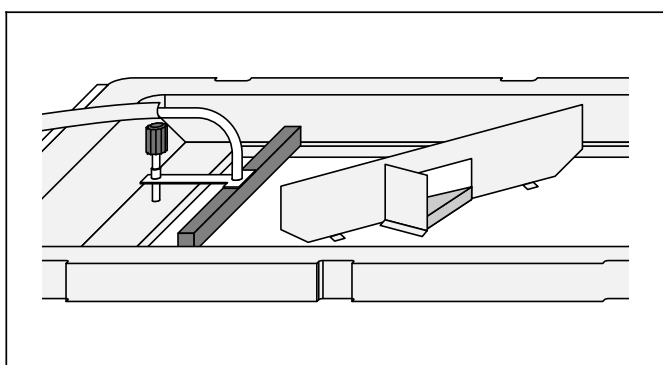
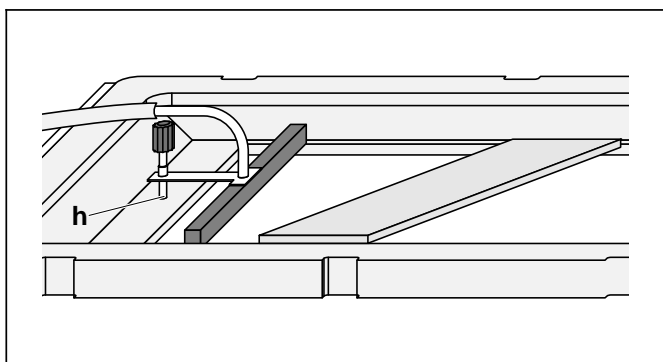

Fig. 2 Experiment setup for refraction of water waves

- a Stroboscope switch
- b Knob (for fine adjustment of stroboscope frequency)
- c Pushbutton (single-wave excitation)
- d Knob (for adjusting amplitude of wave excitation)
- e Knob (for adjusting frequency of wave excitation)
- f Knurled screw (for manually turning stroboscope disk)
- g Observation screen

Fig. 3 Connecting the exciter for straight waves and arranging the plane-parallel acrylic-glass plate

- h Adjusting screw (for setting immersion depth)

Fig. 4 Arranging the exciter for straight waves and the plane-parallel acrylic-glass plate

Fig. 5 Arranging the lens and the exciter for straight waves

Measuring example

a) Refraction of water waves at the edges of the plane-parallel plate:

Table 1: Measuring results for the refraction of water waves

α	β	$\frac{\sin \alpha}{\sin \beta}$	$\frac{\lambda_1}{\text{cm}}$	$\frac{\lambda_2}{\text{cm}}$	$\frac{\lambda_1}{\lambda_2}$
28°	15°	1.8	2.1	1.2	1.8
28°	18°	1.5	1.5	1.0	1.5
28°	24°	1.2	0.8	0.7	1.1

Fig. 6 shows a photograph with a measuring example. Fig. 7 is a schematic representation of this result.

b) Refraction of straight water waves at a prism and at lenses:

Fig. 1 shows photographs with measurement examples.

Results

a) Refraction of water waves at the edges of the plane-parallel plate:

The edge of the plane-parallel plate represents the boundary at which the propagation velocity and the wavelength change. The waves travel more slowly in shallow water than in deep water. The wavelength decreases in the shallower zone.

The direction of propagation changes at the transition from deeper to shallower water. At this transition from deeper to shallower water (from a lower to a higher "refractive index"), the planar waves are refracted toward the axis of incidence.

The law of refraction applies:

$$\frac{\sin \alpha}{\sin \beta} = \frac{\lambda_1}{\lambda_2} = \frac{\lambda_1 \cdot f}{\lambda_2 \cdot f} = \frac{v_1}{v_2}$$

α : Angle of incidence

β : Refractive angle

f : Excitation frequency

λ_1, λ_2 : Wavelengths in zones 1 and 2

v_1, v_2 : Velocities in zones 1 and 2

The magnitude of refraction is a function of the excitation frequency. The wave is refracted less at higher excitation frequencies.

The waves are refracted away from the axis of incidence at the transition from shallow to deep water. The directions of propagation in front of and behind the plane-parallel plate are the same. The absolute values of the refractive angles are the same for both refractive processes.

b) Refraction of straight water waves at the prism:

The direction of the water waves is influenced by the shape of the body. While plane-parallel plates cause parallel shifts, the prism deflects the water waves into a direction other than the original direction of propagation.

Diffraction at the edges of the prism, and the resulting interference phenomena, can interfere with the wave fronts behind the prism.

c) Diffraction of water waves at lenses:

The water waves are refracted as they pass the lens.

After refraction, the "rays" running perpendicular to the wave fronts pass through a single point (the focal point) after refraction at the biconvex lens. The distance between the focal point and the midpoint of the lens (focal length) increases as the excitation frequency and the water depth increase.

In the case of refraction through the biconcave lens, the directional rays are dispersed, so that they seem to originate from a single point in front of the lens. As the excitation frequency and the water depth increase, the directional rays approach the original direction.

The waves are refracted when they enter the zone above the lens, and when leaving this zone. No refraction can be observed while they are within the zone above the lens.

Fig. 6 Refraction of straight water waves at a plane-parallel plate (photograph)

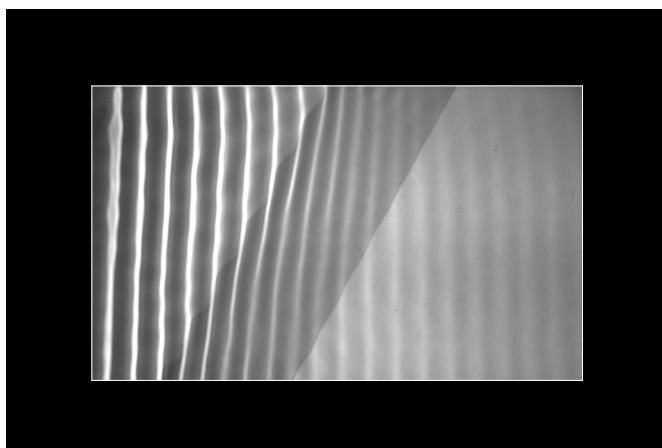

Fig. 7 Diagram of refraction at a planar boundary surface:

n Axis of incidence

α : Angle of incidence (here 28°)

β : Refractive angle (here 15°)

λ_1 : Wavelength in zone 1 (here 2.1 cm)

λ_2 : Wavelength in zone 2 (here 1.2 cm)

