

Moment of inertia and body shape

Objects of the experiment

- Determining the moments of inertia of rotationally symmetric bodies from their period of oscillation on a torsion axle.
- Comparing the periods of oscillation of two bodies having different masses, but the same moment of inertia.
- Comparing the periods of oscillation of hollow bodies and solid bodies having the same mass and the same dimensions.
- Comparing the periods of oscillation of two bodies having the same mass and the same body shape, but different dimensions.

Principles

The moment of inertia is a measure of the resistance of a body against a change of its rotational motion and it depends on the distribution of its mass relative to the axis of rotation. For a calculation of the moment of inertia J , the body is subdivided into sufficiently small mass elements Δm_i with distances r_i from the axis of rotation and a sum is taken over all mass elements:

$$J = \sum_i \Delta m_i \cdot r_i^2 \quad (I).$$

For bodies with a continuous mass distribution, the sum can be converted into an integral. If, in addition, the mass distribution is homogeneous, the integral reads

$$J = M \cdot \frac{1}{V} \cdot \int_V r^2 \cdot dV \quad (II)$$

M : total mass, V : total volume,
 r : distance of a volume element dV from the axis of rotation

The calculation of the integral is simplified when rotationally symmetric bodies are considered which rotate around their axis of symmetry. The simplest case is that of a hollow cylinder with radius R . As all mass elements have the distance R from the axis of rotation, the moment of inertia of the hollow cylinder is

$$J_{\text{hollow}} = M \cdot R^2 \quad (III).$$

In the case of a solid cylinder with equal mass M and equal radius R , Eq. (II) leads to the formula

$$J_{\text{solid}} = M \cdot \frac{1}{V} \cdot \int_0^R r^2 \cdot 2\pi \cdot r \cdot H \cdot dr \quad \text{with } V = \pi \cdot R^2 \cdot H$$

and the result is

$$J_{\text{solid}} = \frac{1}{2} \cdot M \cdot R^2 \quad (IV).$$

Fig. 1 Calculation of the moments of inertia of a hollow cylinder, a solid cylinder and a sphere

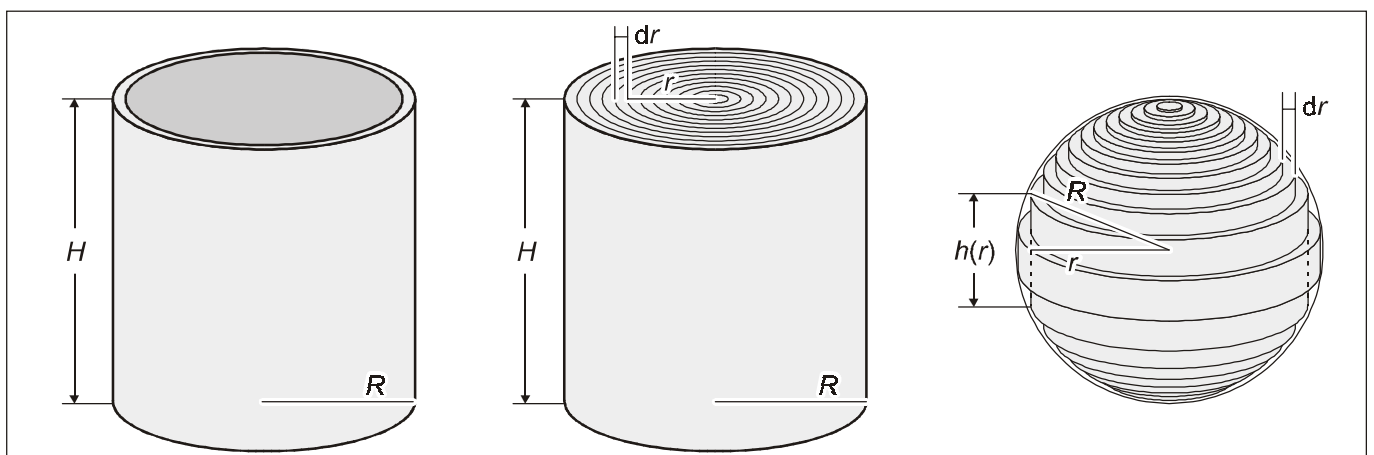

Apparatus

1 torsion axle	347 80
1 set of cylinders for torsion axle	347 81
1 sphere for the torsion axle	347 82
1 stand base, V-shape, 20 cm	300 02
1 stopclock I, 30 s / 15 min	313 07

Setup and carrying out the experiment

The experimental setup is illustrated in Fig 2.

- Put the sphere on the torsion axle, and mark the equilibrium position on the table.
- Rotate the sphere to the right by 180° and release it.
- Start the time measurement as soon as the sphere passes through the equilibrium position and stop the measurement after five oscillations.
- Calculate the period of oscillation T .
- Replace the sphere with the disk, and repeat the measurement.
- Replace the disk with the supporting plate.
- Repeat the measurement with the solid cylinder and then with the hollow cylinder.
- Finally carry out the measurement with the empty supporting plate.

That means, the moment of inertia of a solid cylinder is smaller than that of the hollow cylinder as the distances of the mass elements from the axis of rotation are between 0 and R .

An even smaller value is expected for the moment of inertia of a solid sphere with radius R (see Fig. 1). In this case, Eq. (II) leads to the formula

$$J_{\bullet} = M \cdot \frac{1}{V} \cdot \int_0^R r^2 \cdot 2\pi \cdot r \cdot 2 \cdot \sqrt{R^2 - r^2} \cdot dr \quad \text{with } V = \frac{4\pi}{3} \cdot R^3$$

and the result is

$$J_{\bullet} = \frac{2}{5} \cdot M \cdot R^2 \quad \text{(V).}$$

Thus, apart from the mass M and the radius R of the bodies under consideration a dimensionless factor enters the calculation of the moment of inertia, which depends on the shape of the respective body.

The moment of inertia is determined from the period of oscillation of a torsion axle, on which the test body is fixed and which is connected elastically to the stand via a helical spring. The system is excited to perform harmonic oscillations. If the restoring torque D is known, the moment of inertia of the test body is calculated from the period of oscillation T according to

$$J = D \cdot \left(\frac{T}{2\pi}\right)^2 \quad \text{(VI).}$$

Measuring example

Table 1: list of the bodies under consideration and the measured oscillation periods

Body	$\frac{M}{g}$	$\frac{2 \cdot R}{cm}$	$\frac{5 \cdot T}{s}$	$\frac{T}{s}$
Solid sphere	930	14.5	9.2	1.84
Flat solid cylinder (disk)	340	22	9.6	1.92
Long solid cylinder	330	9	4.7	0.94
Hollow cylinder	360	9	6.2	1.24
Empty supporting plate	—	—	2.9	0.580

Evaluation

a) Qualitative comparison:

Bodies having different masses, but the same moment of inertia:

The sphere and the flat solid cylinder (disk) have different shapes and different masses. They oscillate at approximately the same period, i.e. they have the same moment of inertia.

Hollow body and solid body:

The hollow cylinder and the solid cylinder have approximately the same mass and the same diameter. The periods of oscillation are clearly different, i.e. they have different moments of inertia.

Bodies having the same mass and the same shape but different dimensions:

The flat solid cylinder (disk) and the long solid cylinder have approximately the same mass, but different diameters. They oscillate at clearly different periods, i.e. the moments of inertia are different.

Fig. 2 Experimental setup for determining the moments of inertia of some rotationally symmetric bodies

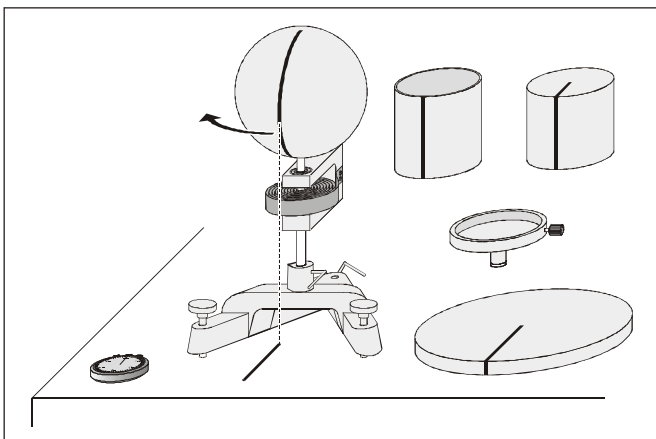

b) Quantitative comparison:

With Eq. (VI), the moments of inertia J can be calculated from the periods T listed in Table 1. The restoring torque D of the torsion axle required for the calculation was determined in the experiment P1.4.5.1:

$$D = 0,023 \frac{\text{Nm}}{\text{rad}}.$$

The results of the calculations are listed in Table 2. The moment of inertia of the empty supporting plate is $J = 0.2 \text{ g m}^2$.

Moreover, the dimensionless factors of Eqs. (III), (IV) and (V) are listed in Table 2 and compared with the values calculated from the measuring data. In all cases (solid sphere, solid cylinder and hollow cylinder), an agreement between measurement and theory is found within the accuracy of measurement.

Table 2: moments of inertia J determined from the oscillation periods

Body	$\frac{J}{\text{g} \cdot \text{m}^2}$	$\frac{J}{M \cdot R^2}$	$\frac{J}{M \cdot R^2}$
Solid sphere	2.0	0.41	$\frac{2}{5}$
Flat solid cylinder (disk)	2.1	0.51	$\frac{1}{2}$
Long solid cylinder	0.32 *	0.48	$\frac{1}{2}$
Hollow cylinder	0.70 *	0.96	1
		Measurement	Theory

* after subtraction of the moment of inertia of the empty supporting plate

Result

The period of oscillation of a body on a torsion axle is determined by the moment of inertia and not by the mass of the body.

Apart from the mass and the radius, the moment of inertia also depends on the shape of a rotationally symmetric body.

If the mass and the shape are equal, the moment of inertia is proportional to the square of the diameter.

A hollow body has a greater moment of inertia than a solid body with the same mass and dimensions.

