

Confirming Newton's first and second laws for linear motions

Recording and evaluating with VideoCom

Objects of the experiments

- Recording the path-time diagrams for one-dimensional motions on a linear air track with VideoCom.
- Studying uniform motions and confirming Newton's first law.
- Studying uniformly accelerated motions and confirming Newton's second law.

Principles

Straight line motion of a mass point:

Newton's laws are the basis for the description of the motions of a mass point. Newton's first law (the law of inertia) states: "Every mass point continues in a state of rest or uniform motion in a straight line unless it is forced by an external force to change its state."

In the course of such a uniform motion, the mass point covers equal path lengths Δs within equal time intervals Δt in a straight line, the value of its velocity

$$v = \frac{\Delta s}{\Delta t} \quad (I)$$

remaining constant. For determining the velocity, a time interval Δt of arbitrary magnitude can be chosen and then the path length Δs covered within this time interval be measured.

In the case of a non-uniform motion, the velocity changes in time, and Eq. (I) gives the mean velocity in the time interval Δt . For determining the instantaneous velocity at a time t , the time interval Δt has to be chosen as small as possible. Therefore

the velocity is more precisely defined by a limit with the time interval approaching zero:

$$v(t) = \lim_{\Delta t \rightarrow 0} \frac{s(t + \Delta t) - s(t)}{\Delta t} = \frac{ds}{dt} \quad (II)$$

Newton's second law relates to the momentum

$$p = m \cdot v \quad (III)$$

of a mass point with mass m or, more precisely, to the momentum vector. It states: "The rate of change of the momentum vector is proportional to the force acting and occurs in the direction in which the force acts."

The unit of the force is usually chosen so that the proportionality factor is equal to 1. From Newton's second law then follows

$$F = \frac{\Delta p}{\Delta t} \quad (IV)$$

for straight line motions or

$$F = m \cdot \frac{\Delta v}{\Delta t} \quad (VI)$$

for constant masses m . Eq. (VI) is known as Newton's equation of motion in the form

$$F = m \cdot a \quad (VII)$$

The quantity

$$a = \frac{\Delta v}{\Delta t} \quad (VIII)$$

is the acceleration of the mass point. It is constant for a uniformly accelerated motion. In other cases, the acceleration at a time t is more precisely defined as the limit

$$a(t) = \lim_{\Delta t \rightarrow 0} \frac{v(t + \Delta t) - v(t)}{\Delta t} = \frac{dv}{dt} \quad (IX)$$

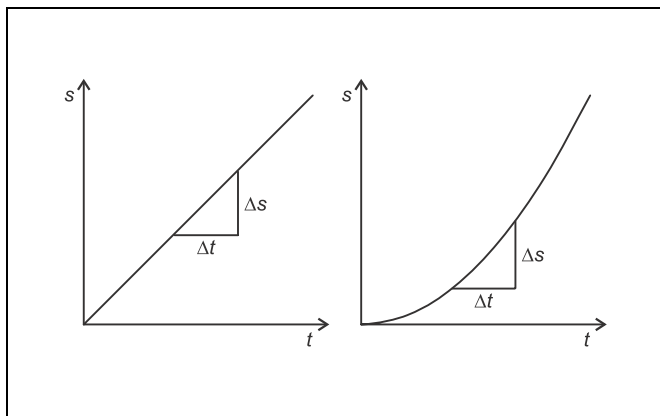

Fig. 1 Path-time diagram of uniform (left) and uniformly accelerated (right) motions

Apparatus

1 linear air track	337 501
1 air supply for air track	337 53
1 power controller	337 531
1 VideoCom	337 47
1 plug-in unit 230 V / 12 V AC / 20 W	562 791
1 camera tripod	300 59
1 stand rod 10 cm	300 40
1 metal scale	311 02

additionally required:

1 PC with Windows 95 / 98 / NT

Recording the motions with VideoCom:

In the experiment, uniform and uniformly accelerated motions of a slider on a linear air track are recorded with the single-line CCD camera VideoCom, which illuminates a retroreflecting foil attached to the slider with LED flashes and images the reflected flashes on a CCD line with 2048 pixels with a camera lens (CCD: charge-coupled device). Up to 80 times per second the present position of the slider is transferred to a computer via a serial interface.

A computer program for VideoCom represents the entire motion of the slider as a path-time diagram and makes possible further evaluation of the measured values. In particular, computation of the velocity

$$v(t) = \frac{s(t + \Delta t) - s(t - \Delta t)}{2 \cdot \Delta t} \quad (X)$$

and of the acceleration

$$a(t) = \frac{v(t + \Delta t) - v(t - \Delta t)}{2 \cdot \Delta t} \quad (XI)$$

can be activated with a mouse click, whereby the user has a choice between several time intervals Δt .

Setup

The experimental setup is illustrated in Fig. 2.

Setting up the linear air track:

- Mount the track rail on the track stand, set it up, and align it horizontally with the adjusting screws (see instruction sheet of the linear air track) using a spirit level.
- Plug the adapter for air supply (**a**) into the air inlet.
- Connect the air supply to the power controller; connect the tubing to the adapter for air supply (see instruction sheet of linear air track).
- Mount the guide pulley with small moment of inertia (**h**) to the stand rod 10 cm at the end of the linear air track.

- Attach the holding magnet with a clamping rider (**c**) near the air inlet, and put the brake (**g**) onto the other end of the track.
- Switch the air supply on, put the slider on the linear air track, and readjust the track with the adjusting screws until the slider remains at rest at several places of the track rail; the air flow should be varied until the parameters are optimised.

Setting up VideoCom:

- Screw VideoCom onto the camera tripod, set it up at a distance of approx. 2 m from the linear air track, and align it in height with the linear air track parallel to the track rail.
- Supply VideoCom with power via the plug-in unit, and connect it to a serial input of the PC (e.g. COM1).
- Connect the holding magnet to VideoCom via two connection leads (see instruction sheet of VideoCom).
- If necessary, install the VideoCom software on a PC with Windows 95/98/NT, call the program "VideoCom Motions" and, if necessary, choose the desired language and the serial interface (see instruction sheet of VideoCom).

Aligning VideoCom:

- Equip two sliders with interrupter flags (**d**) and stick retro-reflecting foil on both of them.
- Move the first slider to the holding magnet, and put the second slider on the linear air track while the air supply is switched off so that the distance between the two interrupter flags is exactly 1 m.
- Click "Intensity Test" in the program "VideoCom Motions".
- Slightly darken the room in order to minimise the background.
- Align VideoCom so that two peaks are visible on the LC display on the housing of the camera or on the screen respectively.
- Get rid of interfering light or reflections so that no other peaks are visible.
- Improve the alignment further until the ratio between the peaks and the background is greater than 5:1 for both sliders.

Connecting the holding magnet:

- Remove the second slider.
- Attach a 1.20 m long piece of thread to the thread holder (**e**) of the first slider, guide it around the pulley and suspend a 1 g weight from it.
- Switch the air supply on, and optimise the air flow.
- Equip the slider with the holding plate and move it to the holding magnet.
- Set the supply voltage for the holding magnet to its maximum value with the adjusting pin (**f**) at the VideoCom housing.
- Adjust the iron core of the holding magnet with the knurled screw (**b**) so that the slider is just kept and starts running immediately after pressing the key START at the VideoCom housing.

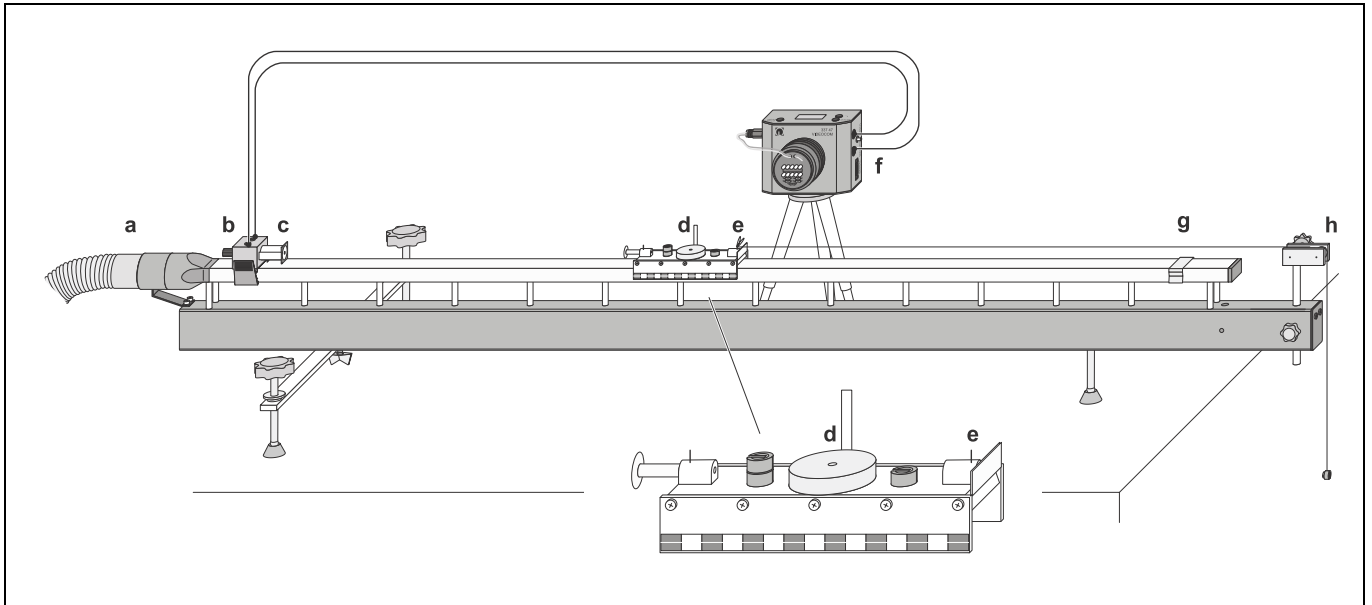



Fig. 2 Experimental setup for recording motion with VideoCom. Here a uniform acceleration with the accelerated mass $m = 100 \text{ g}$ is shown.

Compensating the distortion:

- Change to the representation “Path” in the program “VideoCom Motions”.
- Equip the slider with both interrupter flags (distance = 5 cm).
- Call the menu “Settings/Path Calibration” with the button  or the key F5.
- Enter the values 0 m and 0.05 m as positions of the two interrupter flags in the register “Path Calibration”.
- Click the button “Read Pixels From Display” and activate “Use Calibration”.
- Call the menu “Settings/Path Calibration” anew and enter the following settings in the register “Setpoint Selection”.

Δt	100 ms (10 fps)
Flash	Auto
Smoothing	Standard ($4 \cdot \Delta t$)
Stop measurement	after covering the path
s	e.g. 0.9 m

- Start the measurement with the button  or the key F9, and record the motion of the slider.
- Next click the button “Suggest Linearisation” in the register “Linearisation” of the menu “Settings/Path Calibration”.

If an angle $\alpha \neq 0^\circ$ is displayed, the angle between the linear air track and VideoCom is not yet correct (see Fig. 3):

- Reject the linearisation with the button “Interrupt”.
- Adjust the position of the linear air track by displacing the “right foot”.
- Delete the old measured values with the button  or the key F4, record the motion of the slider, and determine the angle α anew.
- Repeat the procedure until $\alpha = 0^\circ$ is displayed; then activate “Use Linearisation” and take on the displayed distortion δ .

Path calibration:

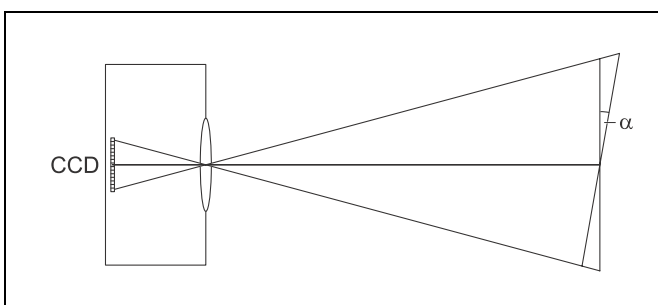

- Equip both sliders with interrupter flags once more, move the first slider to the holding magnet, and put the second slider on the linear air track while the air supply is switched off so that the distance between the two interrupter flags is exactly 1 m.
- Enter the values 0 m and 1 m as positions of the two sliders in the register “Path Calibration” of the menu “Settings/Path Calibration”.
- Click the button “Read Pixels From Display”, and activate “Use Calibration”.

Fig. 3 Scheme of the definition of the angle α between the linear air track and VideoCom.



Carrying out the experiment

a) Uniform motion:

- Delete old measured values with  or F4.
- Remove the thread from the slider, switch the air supply on, and move the slider near the holding magnet.
- Slightly push the slider with a finger, then start the measurement with  or F9, and record the path-time diagram.
- Store the measured values with  or F2 (use a filename that allows you to recognise the file).

b) Uniformly accelerated motion:

- Delete old measured values.
- Attach the thread to the thread holder with a 1 g weight suspended from it and guide the thread around the pulley.
- Move the slider to the holding magnet.
- Start the measurement, record the path-time diagram, and store the measured values.

c) Accelerated motion in dependence on the accelerating force F :

Remark: the accelerated mass is the sum of the total mass of the slider and the total mass suspended from the thread.

- Delete old measured values.
- Equip the slider, e.g., with the impact plate and three 1 g weights in addition so that the total mass m of the slider and the 1 g weight suspended from the thread is 100 g (see instruction sheet of the linear air track).
- Move the slider to the holding magnet, start the measurement, and record the path-time diagram.
- Remove one 1 g weight from the slider, and suspend it from the thread in addition to the other weight.
- Move the slider to the holding magnet, start the measurement, and record the path-time diagram.
- Remove another 1 g weight from the slider, suspend it from the thread in addition to the other weights and record the path-time diagram again. Repeat the measurement with the last 1 g weight from the slider added to the accelerating weights.
- Store the measured values with a new filename.

d) Accelerated motion in dependence on the accelerated mass m :

- Delete old measured values.
- Suspend two 1 g weights from the thread and equip the slider with two 1 g weights. Record the path-time diagram.
- Put an additional 100 g weight on the slider, and record the accelerated motion.
- Repeat the measurement for a second and a third additional 100 g weight.
- Store the measured values with a new filename.

Measuring example and evaluation**a) Uniform motion:**

In Fig. 4 the path-time diagram of the slider is shown for the case of a uniform motion without external force. The path s covered is a linear function of the time t as is confirmed by a fit to a straight line.

From the measured values the instantaneous velocity v can be computed as a function of time by clicking the register "Velocity". This velocity is approximately constant (see Fig. 5) as was to be expected according to the law of inertia.

Remark: The velocity decreases in the course of time as the slider is slightly slowed down by friction. This is the reason why there are small deviations from linearity in the path-time diagram.

b) Uniformly accelerated motion:

In Fig. 6 the path-time diagram of the slider is shown for the case of an acceleration by the constant force F . Here, the path s covered is not a linear function of the time t as is confirmed by a fit to a parabola.

The instantaneous velocity v computed from the measured values is a linear function of time (see Fig. 7). If the instantaneous acceleration a is computed as a function of time by clicking the register "Acceleration", the values obtained are approximately constant (see Fig. 8).

Remark: The acceleration decreases in the course of time because the friction increases with increasing velocity. This is the reason why there are small deviations from linearity in the velocity-time diagram.

c) Accelerated motion in dependence on the accelerating force F :

Fig. 9 is a plot of the accelerated motion of the slider with the constant mass m and different accelerating forces F . Fig. 10 shows the acceleration as a function of time computed from the measured values.

Further evaluation:

- Click the register "Newton" in the menu "Settings/Path Calibration", and choose "Accelerating force F (m constant)" as variable parameter by clicking.
- Determine the mean values of the acceleration a in the acceleration-time diagram, and drag them with the mouse from the status line of the program window (lower edge) into the first column of the table of values of the register Newton.
- Enter the forces F as parameters in the second column.

The result is an $F(a)$ diagram with the measured values lying on a straight line through the origin (see Fig. 11). Thus Eq. (VII) is confirmed for a constant mass m . The slope of the straight line through the origin is

$$\frac{F}{a} = m = 0.1006 \text{ kg (expected value: } m = 0.1 \text{ kg)}.$$

d) Accelerated motion in dependence on the accelerated mass m :

The accelerated motion with a constant force F for different masses m is shown in Fig. 12. Fig. 13 shows the acceleration computed from the measured values.

Further evaluation:

- Choose "Mass m (as a function of $1/a$)" as variable parameter in the register "Newton".
- With the mouse drag the mean values of the accelerations a into the first column of the table of values of the register Newton.
- Enter the masses m in the second column.

The measured values lie on a straight line through the origin in the resulting $m(1/a)$ diagram (see Fig. 14). Thus Eq. (VII) is confirmed for a constant force F . The slope of the straight line through the origin is

$$\frac{m}{\frac{1}{a}} = F = 0.0192 \text{ N (expected value: } F = 0.0196 \text{ N)}$$

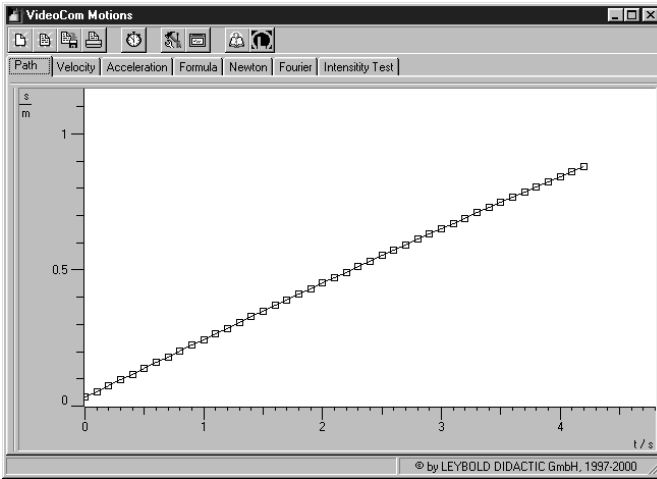

Fig. 4 Path-time diagram of a uniform motion of the slider recorded with VideoCom.

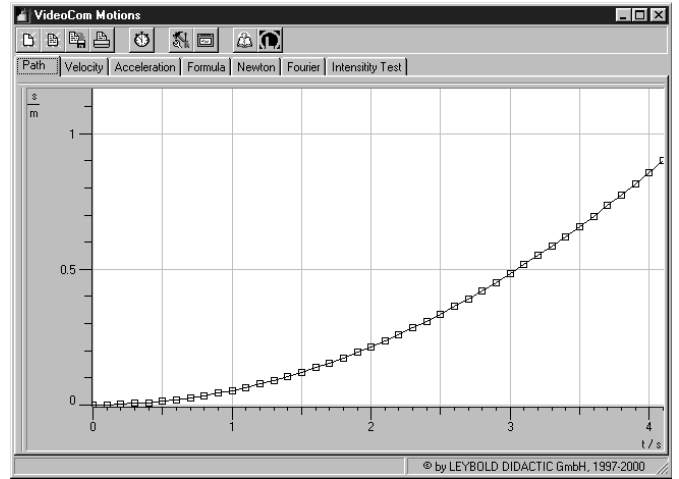

Fig. 6 Path-time diagram of a uniformly accelerated motion of the slider recorded with VideoCom.

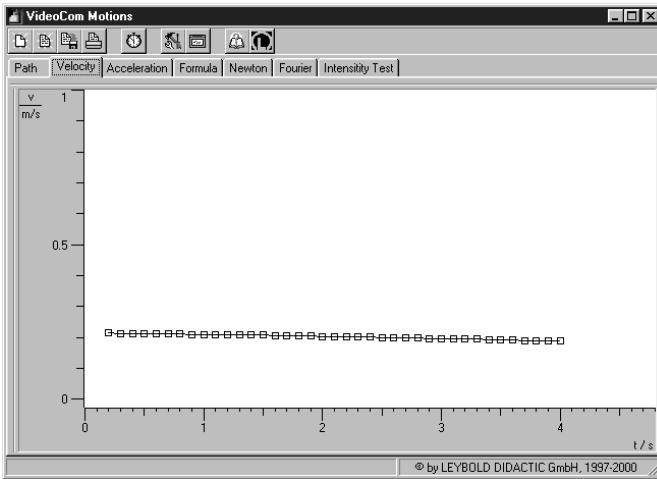

Fig. 5 Velocity-time diagram corresponding to Fig. 4.

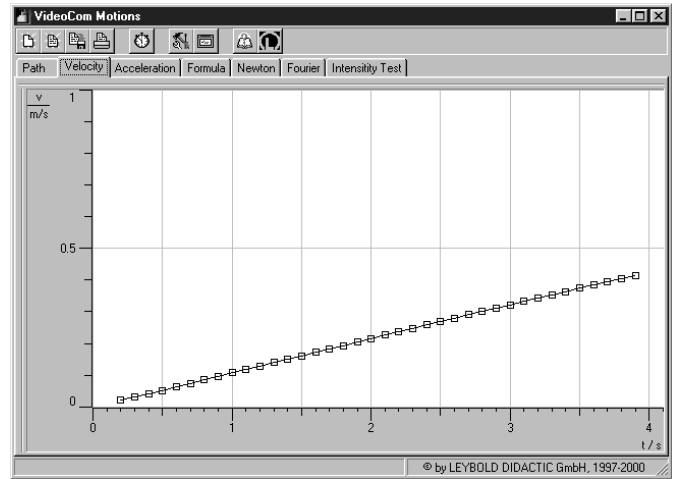

Fig. 7 Velocity-time diagram corresponding to Fig. 6

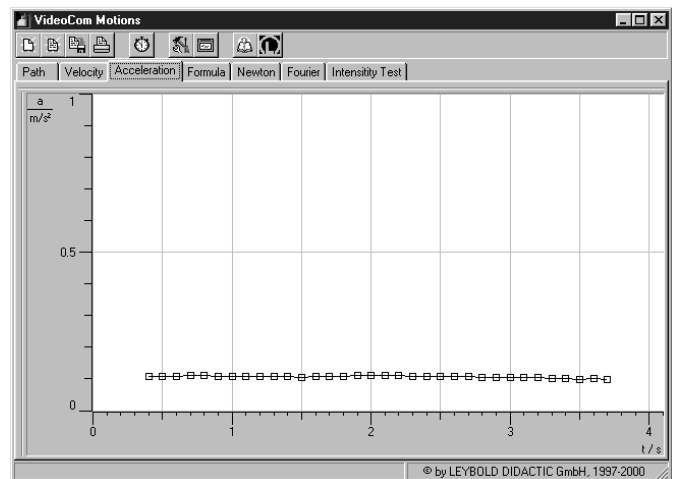

Fig. 8 Acceleration-time diagram corresponding to Fig. 6

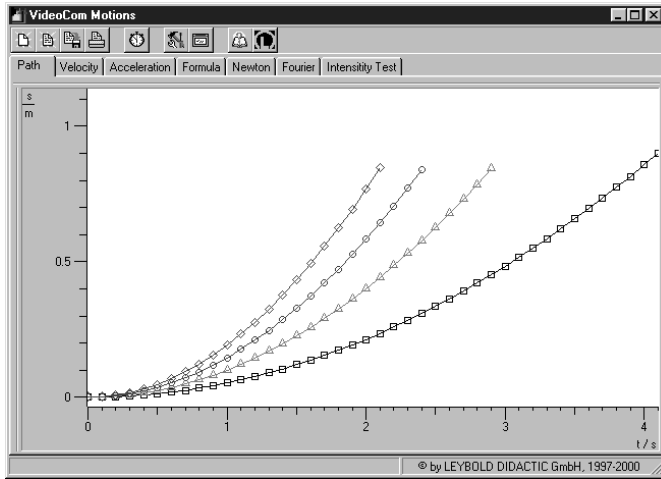

Fig. 9 Path-time diagram of the uniformly accelerated motion with the constant mass $m = 100 \text{ g}$ ($F = 0,0098 \text{ N}$ (\square), $0,0196 \text{ N}$ (\triangle), $0,0294 \text{ N}$ (\circ), $0,0392 \text{ N}$ (\diamond)).

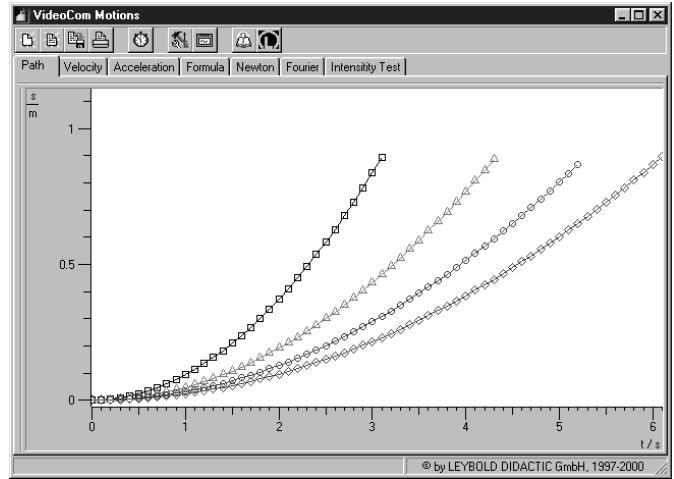

Fig. 12 Path-time diagram of the uniformly accelerated motion with the constant accelerating force $F = 0,0196 \text{ N}$ ($m = 100 \text{ g}$ (\square), 200 g (\triangle), 300 g (\circ), 400 g (\diamond)).

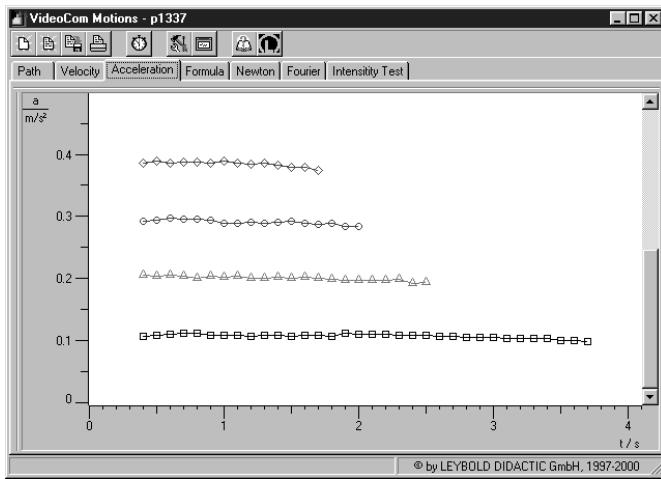

Fig. 10 Acceleration-time diagram corresponding to Fig. 9

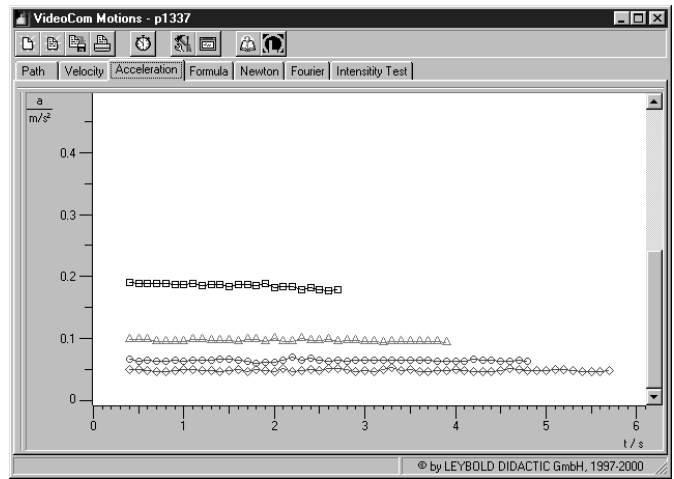

Fig. 13 Acceleration-time diagram corresponding to Fig. 12

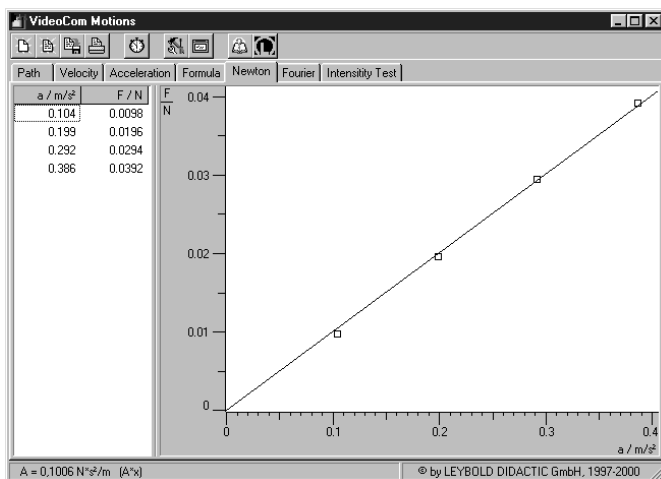

Fig. 11 $F(a)$ diagram and table of values for the constant accelerated mass $m = 100 \text{ g}$.

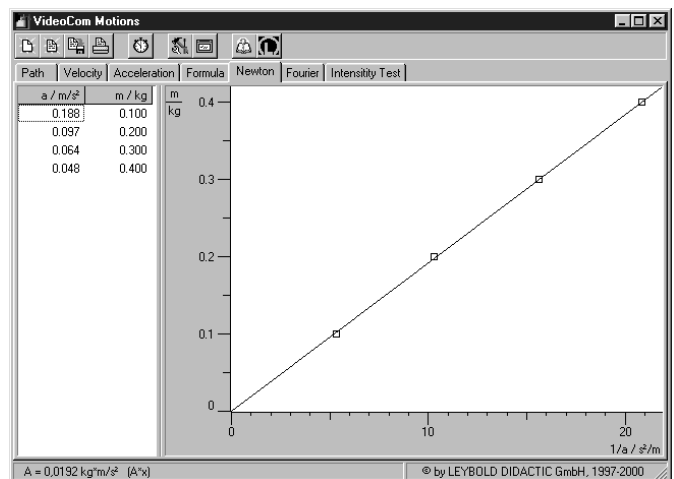

Fig. 14 $m(1/a)$ diagram and table of values for the constant accelerating force $F = 0.0196 \text{ N}$.